

Healthcare in the age of technology

Outstanding technology solutions that keep patients and healthcare practitioners connected



An aging population coupled with a predicted **shortage of 15 million** healthcare professionals by 2035 is putting strain on the industry to be able to service the needs to the population¹



Challenges with social distancing and the need to service rural locations is **accelerating** the rollout of telemedicine¹

63%

Survey's across the US, UK, France, Germany, Japan and China show that roughly 70% of those surveyed have used some form of telemedicine and **63%** of those who had used it found it was a good or excellent experience¹

33%

Remote Healthcare is expected to grow by **33%** each year until 2025, with 46% of that market being represented by real-time virtual health¹

PROFESSIONAL AUDIO SOLUTIONS

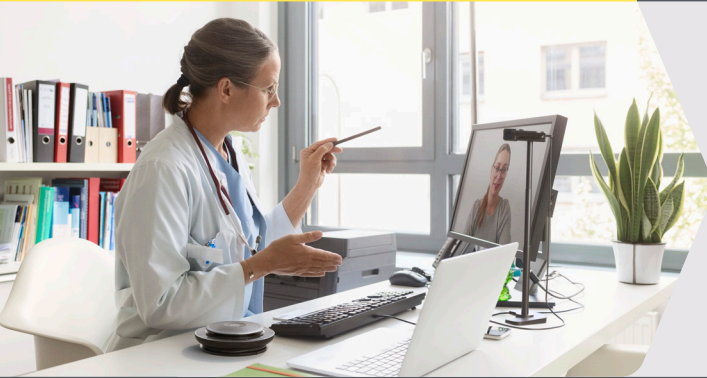

SPEAK 750

Compact portable speakerphone offers crystal-clear audio with impressive battery life, and flexible connectivity for remote healthcare



EVOLVE2 65

Jabra Evolve2 65 is engineered to keep you agile. Supremely comfortable with outstanding battery life, call performance and noise isolation



INTELLIGENT VIDEO SOLUTIONS

PANACAST

Plug-and-play panoramic-4K video with a 180° field of view

Vivid HDR ensures the best video experience, even under varying lighting conditions

Compatible with all leading video and audio-conferencing solutions

Easily portable and mobile

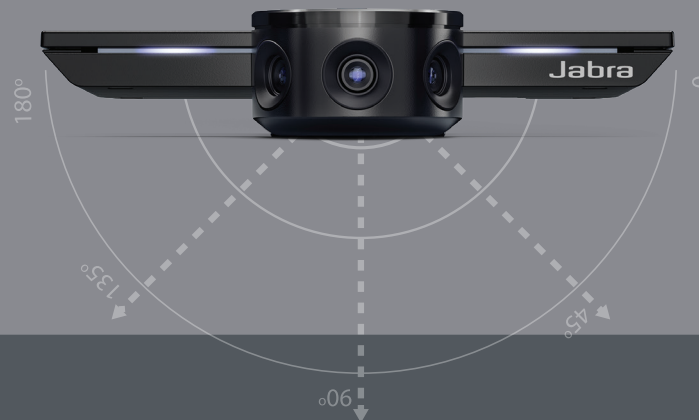

¹Jabra Customer Database Survey April 2020 ²Jabra Knowledge Worker Survey 2017